

# Body Worn Camera DSJ-U1-LPN

## KEDACOM

### Quick Start Guide

#### I. Preface

Thank you for purchasing our product. If there are any questions, or requests, please do not hesitate to contact us. Every effort has been made to ensure the accuracy and validity of this Guide. Any update of this Guide is subject to change without notice. For the latest document, please contact the dealer.

#### II. Safety Instruction

These instructions are intended to ensure that the user can use the product correctly to avoid danger or property loss. Please read this Guide carefully before using the product, and keep it properly for future reference. If the product cannot work normally or is damaged because the user does not follow the safety instructions, we shall not assume any responsibility.

DSJ-U1-LPN is a custom precise electronic device. To prevent damage on device caused by improper operation during using, please follow the instructions below:

- While shipping the camera, pack it in the factory packing or use materials with equivalent quality.
- If the product does not work properly, please contact your dealer or the nearest service center. Never attempt to disassemble or repair the product yourself in any way.
- Use only the attached battery or battery and adaptor authenticated by this company. Never electrify the device with power adaptor over the rated voltage (5V); otherwise, the device may be damaged.

**[Notice]** Never let any liquid flow into the camera. If any liquid enters the device by accident, pull out the battery immediately. If the device is not used for a long time, take out the battery. Do not expose the camera in the environment not defined in this Guide.

- Do not use the device under temperature out of the specified range (-30degree ~ 60 degree) or the battery may be damaged. Never make the battery short circuit, decomposed or throw it into fire. Do not shield the heat dissipation part of the device.

**[Notice]** This device is equipped with replaceable battery and the design of the battery compartment is intrinsically safe. If installing a wrong model battery or the polarity is inverted, it may cause explosion or fire.

#### III. Brief Introduction

KEDACOM body worn camera DSJ-U1 reaches the industrial protection level IP67. If you want to open the battery cover, please keep the device dry and away from water or other liquids; when recovering the battery cover, make sure all sides are tightly locked; otherwise, its waterproofness may be affected.

#### IV. Installation

#### Install Battery

The device is equipped with replaceable battery. When replacing the battery or not using the device for a long time, please pull out the battery. Open the back cover and pull out the battery as the following picture indicates.

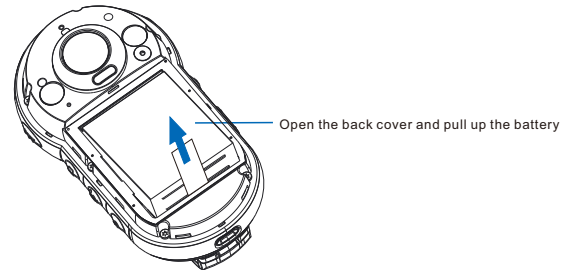

#### Install SIM Card and TF Card

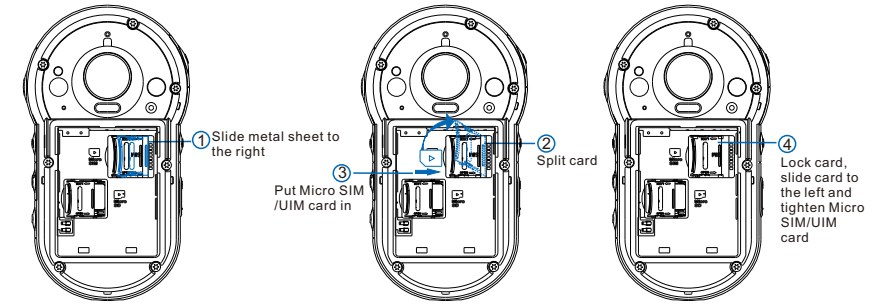

After pulling out the battery, insert Micro SIM/UM card and TF card into the device. **[Notice]** Some models do not support SIM card slot. The method of installing a TF card is the same as that to install a Micro SIM/UM card.

#### V. Appearance

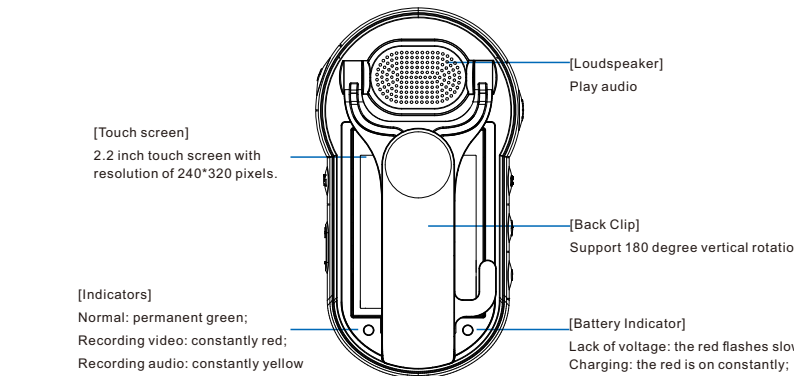
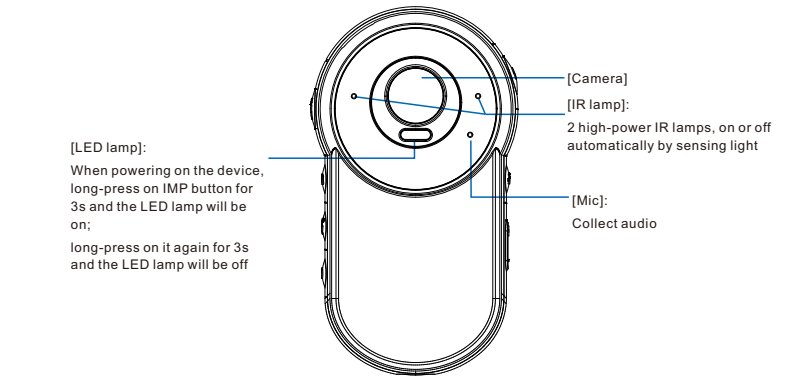

[PTT] (push to talk)  
Press to talk; release to stop talking

[Photograph]  
Under the viewing mode, press it to take a photo of current image in the viewing scene; under the recording mode, press it to capture the image in the video record

[Power Supply]  
When the device is powered off, long-press on it for 3s to power on the device; when the device is powered on, long-press on it for 3s to power it off

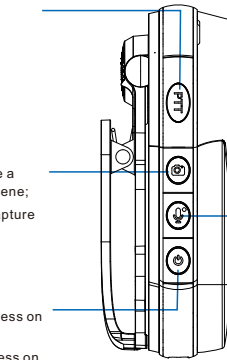

[Audio Recording]: Under the viewing mode, press it to start audio recording; under audio recording mode, re-press it to finish audio recording and save it.

[Video Recording]  
Under the viewing mode, press it to start video recording; Under video recording mode, re-press it to stop recording and save the video record.

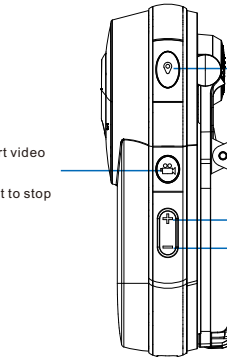

[IMP] Under any mode, press IMP to trigger alarm snapshot (with alarm OSD). Under video or audio recording mode, press this button to mark the file as important one; under any mode, long-press on IMP for 3s and the LED lamp will be on to compensate light; long-press again for 3s and the LED lamp will be off

[Volume +]  
[Volume -]  
[Volume Adjustment] Press "+" or "-" to adjust volume.

## VI. Interface Functions

Power on the device and enter the interface of viewing. Detailed operations can be referred to in *Body Worn Camera DSJ-U1-LPN User Manual*.

**Status bar:**  
show time, status of VMS registration, location icon, bluetooth, WiFi, battery and SIM card status

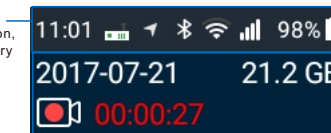

**Information bar:**  
show date, record duration and available storage of the device.



**Viewing area:**  
image displaying in the pattern of 16:9.



**Setting:**  
configure system parameters and information displayed

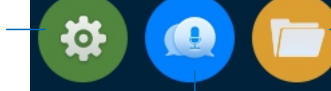

**File management:**  
view video, audio or picture files

**VLine:**  
talkback, live video and audio recording, contacts management



5

## Appendix: Use of Charging Box and Charging Station

A body worn camera can be charged with either a charging box or a 6-set charging station together with other body worn cameras.

- When charging the battery of one body worn camera, only have to put the battery inside the charging box and connect the box to the power supplying device with USB wire.

Put the battery inside the charging box

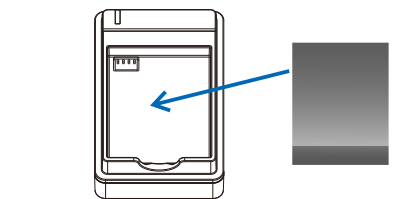

Connect the charging box to the power supplying device with USB wire

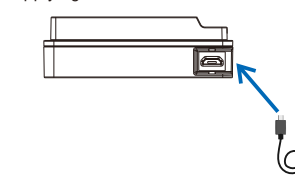

- Before charging multiple body worn cameras with the 6-set charging station, install the charging station and connect wires first, and then put the body worn cameras inside it.

### Dimensions of 6-Set Charging Station

Unit: mm

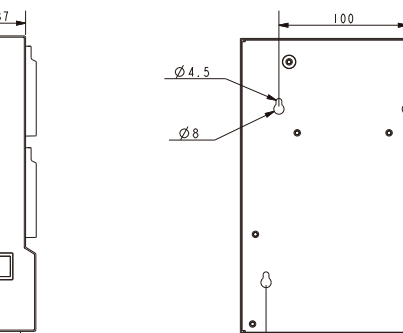
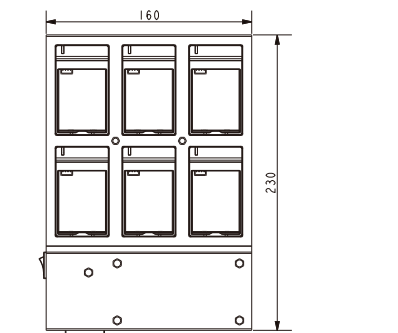

6

## Installation and Using of Charging Station

① Drill holes on the wall

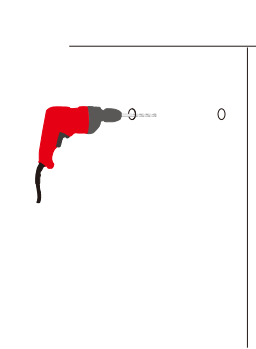

② Insert the plastic expansion tubes into the holes and turn in the screws to fix them

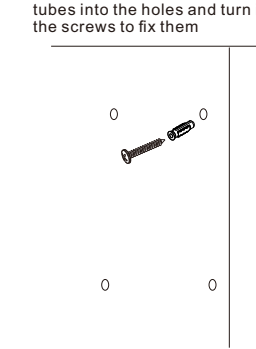

③ Hang the charging station on the screws through the holes on its back and pull down the charging station to make it fixed.

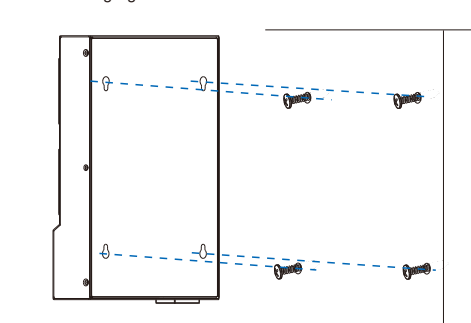

④ Connect wires of the charging station, put the BWC inside the slot and turn on the general power supply to charge multiple BWCs simultaneously.

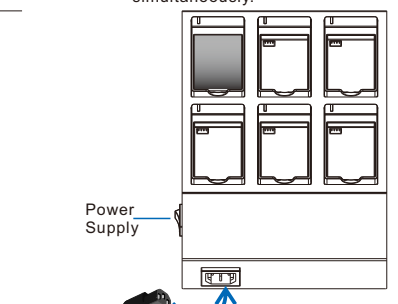

7

## Kedacom Two (2) Year Limited Hardware Warranty

### WHAT IS COVERED BY THIS WARRANTY?

Kedacom warrants the Kedacom-branded hardware product and accessories contained in the original packaging (hereinafter referred to as "Kedacom Product") against defects in materials and workmanship when used normally in accordance with Kedacom's published guidelines for a period of TWO (2) YEARS from the date of original retail purchase in areas other than mainland China by the end-user purchaser (hereinafter referred to as "Warranty Period"). For the Kedacom Product purchased in mainland China, see the simplified Chinese version of this warranty for details. Kedacom's published guidelines include but are not limited to information contained in technical specifications, user guides, and service communications. The preceding applies unless otherwise agreed in the contract.

### WHAT IS NOT COVERED BY THIS WARRANTY?

This warranty does not apply to any non-Kedacom branded hardware products or any software, even if packaged or sold with Kedacom hardware. Manufacturers, suppliers, or publishers, other than Kedacom, may provide their own warranties to you but Kedacom, in so far as permitted by law, provides their products "AS IS". Software distributed by Kedacom with or without the Kedacom brand (including, but not limited to system software) is not covered by this warranty. Please refer to the licensing agreement accompanying the software for details of your rights with respect to its use. Kedacom does not warrant that the operation of the Kedacom Product will be uninterrupted or error-free. Kedacom is not responsible for damage arising from failures to follow instructions relating to the Kedacom Product's use.

This warranty does not apply: (a) to consumable parts, such as batteries, unless failure has occurred due to a defect in materials or workmanship; (b) to cosmetic damage, including but not limited to scratches, dents, and broken plastic on ports; (c) to damage caused by use with another product; (d) to damage caused by acts outside the control of Kedacom, including without limitation acts of God, accidents, abuse, misuse, fire, storms, earthquakes, flood, or other external cause; (e) to damage caused by exposure of the product to heat, bright light, sun, liquids, sand, or other contaminants; (f) to damage caused by operating the Kedacom Product outside Kedacom's published guidelines; (g) to damage caused by service (including upgrades and expansions) performed by anyone other than a representative of Kedacom, Kedacom employee, or authorized Kedacom agent; (h) to an Kedacom Product that has been modified to alter functionality or capability without the written permission of Kedacom; (i) to defects caused by normal wear and tear or otherwise due to the normal aging of the Kedacom Product, or (j) if any serial number has been removed or defaced from the Kedacom Product.

### YOUR RESPONSIBILITIES

If your Kedacom product is capable of storing data and other information, you should make periodic backup copies of the information contained on the storage media to protect the contents and as a precaution against possible operational failures.

Before receiving warranty service, Kedacom or its authorized agents may require that you furnish proof of purchase details, respond to questions designed to assist with diagnosing potential issues, and follow Kedacom's procedures for obtaining warranty service. Before submitting your Kedacom Product for warranty service, you should maintain a separate backup copy of the contents of its storage media, remove all personal information that you want to protect, and disable all security passwords.

During warranty service, it is possible that the contents of the Kedacom product's storage media will be lost, replaced or reformatted. In such an event, Kedacom and its authorized agents are not responsible for any loss of data or other information contained on the storage media or any other part of the Kedacom product serviced.

Following warranty service, your Kedacom Product or a replacement product will be returned to you as your Kedacom Product was configured when originally purchased, subject to applicable updates. You will be responsible for reinstalling all other data and information. Recovery and reinstallation of other data and information are not covered under this warranty.

### WHAT WILL KEDACOM DO IF THE WARRANTY IS BREACHED?

If during the Warranty Period, you submit a valid claim to Kedacom or an authorized Kedacom agent, Kedacom will, at its option, (i) repair the Kedacom Product using new or previously used parts that are equivalent to new in performance and reliability, or (ii) exchange the Kedacom Product for a refund of your purchase price.

A Kedacom replacement part or product, including a user-installable Kedacom part that has been installed in accordance with instructions provided by Kedacom, assumes the remaining warranty of the Kedacom Product or ninety (90) days from the date of replacement or repair, whichever provides longer coverage for you. When a product or part is replaced or a refund provided, any replacement item becomes your property and the replaced or refunded item becomes Kedacom's property. Kedacom reserves the right to refund the purchase price as its exclusive warranty remedy.

### HOW TO OBTAIN WARRANTY SERVICE?

To seek warranty service, please contact a local authorized Kedacom agent. When contacting the agent via telephone, other charges may apply depending on your location.

### User Information

Complete the form below and keep for ready reference.

User Name:	
Address:	Postal Code:
Tel:	Mobile:
Fax:	E-Mail:
Product Name:	Product Model:
Date of Purchase:	

Overseas Hotline: +86-0512-8896 9861

www.kedacom.com

**KEDACOM**

苏州科达科技股份有限公司  
Suzhou Keda Technology Co., Ltd. China: No. 131, Jinshan Road, New Hi-Tech District, Suzhou, Jiangsu 215011  
Tel: +86-512-6841 8188 Fax: +86-512-68412699